

Dispersion Analysis of a Microstrip-Based Negative Refractive Index Periodic Structure

Anthony Grbic, *Student Member, IEEE*, and George V. Eleftheriades, *Senior Member, IEEE*

Abstract—We present the complete band structure of a negative refractive index metamaterial based on the concept of dual transmission lines. The metamaterial is a two-dimensional (2-D) microstrip periodic structure that has cell dimensions much smaller than the wavelength of operation. It can therefore be considered as an effective medium. First, the dispersion characteristics of the metamaterial are explained by way of a 2-D loaded transmission line representation. Subsequently, full-wave analysis is utilized to reveal additional modes that can be excited in the metamaterial.

Index Terms—Left-handed media, loaded transmission lines, metamaterials, negative refractive index, periodic structures.

I. INTRODUCTION

NEWLY developed composite materials with simultaneously negative, frequency dependent values of permittivity and permeability have received much attention in the past few years [1]–[4]. These materials exhibit counter-intuitive electromagnetic phenomena such as reversed refraction, as well as reversals of the conventional Doppler shift and Cherenkov radiation [5]. As a result, they can be referred to as negative refractive index (NRI) metamaterials. Veselago termed these materials “left handed media” since the wave vector \vec{k} forms a left-handed triplet with \vec{E} , \vec{H} [5]. The first implementation of a NRI metamaterial combined an array of metallic wires to attain negative effective permittivity with an array of split-ring resonators (SRRs) to achieve negative permeability [4]. It was used to demonstrate a “left handed” propagation band and negative refraction.

Recently, a NRI metamaterial in the form of a two dimensional L - C loaded transmission line network (shown in Fig. 1) was also used to demonstrate reversed refraction and focusing at microwave frequencies [6], [7]. This network supports backward waves and has been termed a “dual transmission line” since it is of a high-pass configuration, as opposed to the low-pass representation of a conventional transmission line. The NRI metamaterial was implemented by loading a grid of printed microstrip lines with lumped element (packaged) series capacitors and shunt inductors [7]. In addition, a printed one-dimensional (1-D) dual transmission line network supporting fast backward waves was shown to exhibit backward wave radiation from the fundamental spatial harmonic—a characteristic analogous to reversed Cherenkov radiation [8],

[9]. However, the analysis in previous work was restricted to 1-D and the transmission line based models considered only propagation along the structure’s principal axes.

In this letter, we consider a microstrip-based two-dimensional (2-D) periodic structure that is compatible with standard photolithographic techniques and exhibits the propagation characteristics of a medium with negative permittivity and permeability over a wide bandwidth. Unlike the metamaterial in [4], the proposed structure does not employ SRRs. Initially, its operation is explained using a 2-D transmission line representation that considers all directions of propagation. Subsequently, the dispersion characteristics of the periodic structure are computed using full-wave analysis. In this letter, we present the complete band structure of a NRI metamaterial realized based on the dual transmission line concept of [6]–[9].

II. PRINCIPLE OF OPERATION

The unit cell of a microstrip periodic structure that implements the dual transmission line network of Fig. 1 is shown in Fig. 2. Much like in a continuous material with negative parameters (ϵ and μ), the phase velocity of an electromagnetic wave guided by the periodic structure is directed toward its source while its energy propagates away from the source. Since energy flow and phase velocity occur in opposite directions, these waves are often referred to as backward waves. It is in fact this backward-wave (BW) propagation that is responsible for the counter-intuitive electromagnetic phenomena and focusing properties associated with negative refractive index materials [5], [6], [8], [10]. The operation of the periodic structure is easily understood from its dual transmission line representation illustrated in Fig. 1. The dispersion relation of the dual transmission line network can be derived by applying Bloch boundary conditions to the voltages and currents at the ports of the unit cell. As shown in Fig. 1, the voltage and current at one port of the cell can be related to those at the opposite port by a wave number k_x or k_y in the x and y directions, respectively

$$V_1 = V_x, \quad V_3 = V_x e^{-jk_x d}, \quad I_1 = I_x, \quad I_3 = I_x e^{-jk_x d} \quad (1)$$

$$V_2 = V_y, \quad V_4 = V_y e^{-jk_y d}, \quad I_2 = I_y, \quad I_4 = I_y e^{-jk_y d} \quad (2)$$

where V_1 to V_4 and I_1 to I_4 represent the voltages and currents at the four ports of the unit cell. Kirchhoff’s voltage and current laws can then be used to form a system of two linear homogeneous equations in V_x and V_y . The dispersion relation of the dual

Manuscript received June 17, 2002; revised October 10, 2002. The review of this letter was arranged by Associate Editor Dr. Rüdiger Vahldieck.

The authors are with the Edward S. Rogers Sr. Department of Electrical and Computer Engineering, University of Toronto, Toronto, ON M5S 3G4, Canada (e-mail: gelefth@waves.utoronto.edu).

Digital Object Identifier 10.1109/LMWC.2003.811042

Fig. 1. Two-dimensional L - C dual transmission line network.

Fig. 2. Unit cell of proposed NRI metamaterial.

transmission line network is simply the characteristic equation of this system of homogeneous equations

$$\begin{aligned} & \sin^2\left(\frac{k_x d}{2}\right) + \sin^2\left(\frac{k_y d}{2}\right) \\ &= \frac{1}{2} \left[2 \sin\left(\frac{\beta d}{2}\right) - \frac{1}{Z_o \omega C} \cos\left(\frac{\beta d}{2}\right) \right] \\ & \cdot \left[2 \sin\left(\frac{\beta d}{2}\right) - \frac{Z_o}{2\omega L} \cos\left(\frac{\beta d}{2}\right) \right] \end{aligned} \quad (3)$$

where β is the propagation constant of the interconnecting transmission line sections and Z_o is their characteristic impedance, d is the unit cell dimension, ω is the radial frequency, L is the shunt loading inductor and C is the series loading capacitor. For the case where the interconnecting transmission line sections are electrically short and the phase delay per unit cell is small, thus ensuring nearly isotropic propagation, the dispersion relation of (1) reduces to

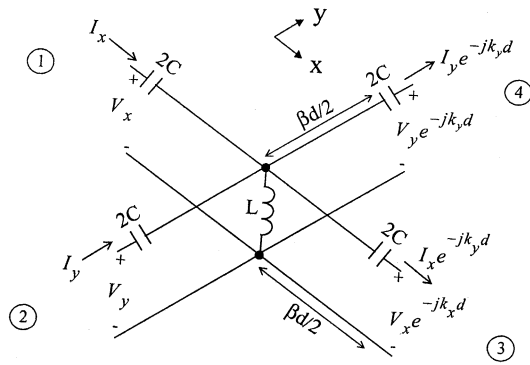
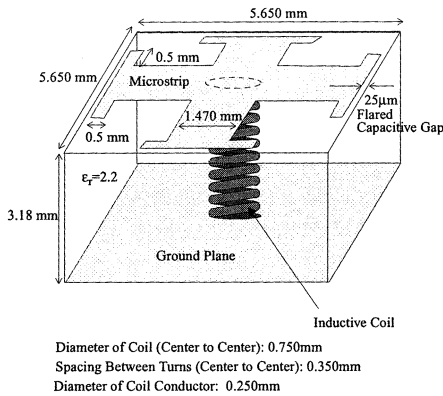
$$k_x^2 + k_y^2 \approx 2 \left[\beta - \frac{1}{Z_o \omega C d} \right] \left[\beta - \frac{Z_o}{2\omega L d} \right]. \quad (4)$$

Letting $k_x = k \cos \theta$ and $k_y = k \sin \theta$ where θ is the angle between the wave vector, \vec{k} , and the x axis, the dispersion relation becomes

$$k^2 \approx \frac{1}{\omega^2 L C d^2} - \beta d \left(\frac{2}{\omega Z_o C d^2} + \frac{Z_o}{\omega L d^2} \right). \quad (5)$$

The group velocity ($v_g = \partial\omega/\partial k$), is simply

$$v_g \approx -k\omega^3 L C d^2. \quad (6)$$

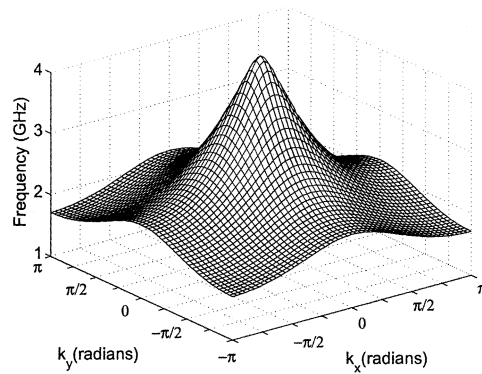
Fig. 3. Dispersion characteristic of L - C dual TL network.

From (6), it is clear that the wave vector, \vec{k} , (as well as the phase velocity) and group velocity are antiparallel. The group velocity is parallel to energy flow for this particular structure since it is lossless and no anomalous dispersion occurs. Consequently, energy flow and phase velocity occur in opposite directions and thus backward waves are supported by the structure. The dispersion characteristic in Fig. 3 shows the lowest passband for the infinite dual transmission line structure of Fig. 1 with representative loading L , C element values and transmission line dimensions. Fig. 3 shows that the group velocity v_g (the gradient to the dispersion surface) is antiparallel to the phase velocity in the lowest passband, again indicating that backward waves are supported. Such a propagation band has been referred to as a “left handed” frequency band [4]. The mechanism by which the shunt inductors and series capacitors provide the negative effective permittivity and permeability is described in [6]–[8].

III. MICROSTRIP BASED NRI PERIODIC STRUCTURE

In the NRI periodic structure of Fig. 2, microstrip lines are used for the interconnecting transmission line sections. The flared gaps in the microstrip lines serve as the series capacitors while the coils connecting the microstrip lines to the ground plane act as the shunt inductors of Fig. 1. A readily available substrate of relative permittivity 2.2 and 125 mil (3.175 mm) in height is assumed in the simulations. The structure depicted in Fig. 2 was simulated using Ansoft’s HFSS, a commercial finite element method electromagnetic solver. The simulated dispersion characteristics of the structure are shown in Fig. 4. As shown, the periodic structure’s backward-wave frequency band of operation overlaps with the lowest passband predicted by the 2-D dual transmission line network theory of Fig. 3. This lowest passband or “left handed” band extends from 1.77 GHz to 4.44 GHz. Within this frequency band, the unit cell dimension is electrically small, therefore the structure operates in the long wavelength regime. In other words, the wavelength of operation is much longer than the dimension of the unit cell. At frequencies within this “left handed” band where the per-unit-cell phase delay ($kd \ll 1$) is small, the periodic structure can be considered as an effective medium since it appears homogeneous and nearly isotropic. As a result, the electromagnetic properties of the structure can be expressed in terms of effective electric permittivity and magnetic permeability.

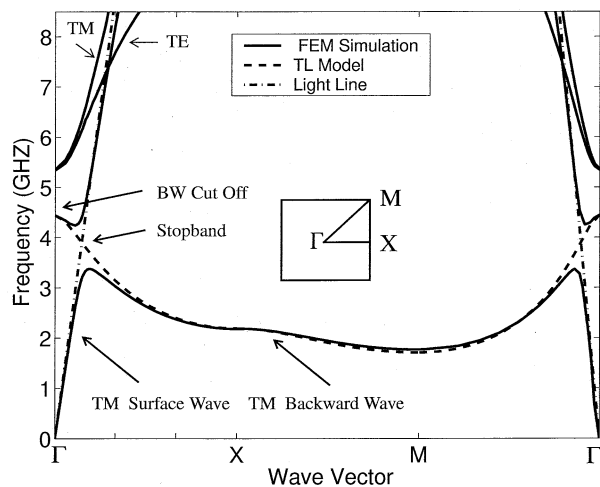

Fig. 4. Dispersion characteristic of proposed structure (TE, TM waves with respect to vertical z -axis).

IV. BAND STRUCTURE

The simulated dispersion characteristics of Fig. 4 show the backward-wave frequency band and some of the additional modes that can be excited in this structure. These modes have not been discussed in previous work on negative refractive index L - C transmission line networks. At low frequencies, the surface impedance of the NRI periodic structure is inductive due to the coils on the grounded substrate and therefore a TM surface wave is supported. This surface wave exists predominantly above the surface of the periodic structure and has a propagation constant very close to that of free-space. Therefore, as the frequency is increased, the propagation constant of the TM surface wave follows the light line as shown in Fig. 4.

At 1.77 GHz, the periodic structure begins to resonate. At this frequency, the inductive coils resonate with the flared capacitive gaps they are connected to by the microstrip lines. Above this resonance, a TM backward-wave is supported in addition to the TM surface wave guided by the inductive surface. With a progressive increase in frequency, the phase delay per unit cell of the backward-wave increases from $k_x d = k_y d = -\pi$ at resonance (point M), as was also suggested by the dispersion relation of the dual transmission line network of Fig. 3. When the backward wave intersects the light line, contradirectional coupling occurs between the backward wave and the forward traveling surface wave. This contradirectional coupling causes the backward and forward TM modes to form a stopband. Above and below the stopband, the backward wave and TM surface wave join to form continuous bands. This stopband is not captured by the simple 2-D transmission line representation of Fig. 1. At 4.44 GHz, the backward-wave is cut off due to the resonance between the distributed shunt capacitance of the interconnecting microstrip lines and the loading inductive coils. From an effective medium perspective, the effective permittivity of the struc-

ture is at the onset of becoming positive and the backward wave is cut off.

At low frequencies, TE surface waves are cut off since the surface impedance of the periodic structure is inductive. However, as the frequency is increased, the surface impedance becomes capacitive and TE surface-wave modes are supported. As shown in Fig. 4, the fundamental TE mode begins at 5.35 GHz. Since the E-field has no vertical component for TE modes, this mode remains largely unaffected by the presence of the vertical coils. Therefore, the fundamental TE mode is essentially the TE mode supported by the proposed structure without the vertical conducting coils. A TM mode also exists above 5.35 GHz. This TM wave is leaky due to the capacitive surface impedance of the structure.

V. SUMMARY

The dispersion characteristics of a negative refractive index metamaterial supporting 2-D waves have been presented. The metamaterial is a periodic microstrip structure that is based on the concept of dual transmission lines and does not employ split-ring resonators. As a result, it offers a large bandwidth of NRI operation. The corresponding dispersion characteristics were first explained with 2-D loaded transmission line theory. Subsequently, full-wave analysis was utilized to reveal the metamaterial's complete band structure.

REFERENCES

- [1] D. R. Smith, W. J. Padilla, D. C. Vier, S. C. Nemat-Nasser, and S. Schultz, "Composite medium with simultaneously negative permeability and permittivity," *Phys. Rev. Lett.*, vol. 84, pp. 4184–4187, May 2000.
- [2] J. B. Pendry, "Negative refraction makes a perfect lens," *Phys. Rev. Lett.*, vol. 85, pp. 3966–3969, Oct. 2000.
- [3] D. R. Smith and N. Kroll, "Negative refractive index in left-handed materials," *Phys. Rev. Lett.*, vol. 85, pp. 2933–2936, Oct. 2000.
- [4] R. A. Shelby, D. R. Smith, and S. Schultz, "Experimental verification of a negative index of refraction," *Science*, vol. 292, pp. 77–79, Apr. 2001.
- [5] V. G. Veselago, "The electrodynamics of substances with simultaneously negative values of ϵ and μ ," *Sov. Phys. Usp.*, vol. 10, pp. 509–514, Jan.–Feb. 1968.
- [6] A. K. Iyer and G. V. Eleftheriades, "Negative refractive index metamaterials supporting 2-D wave propagation," in *IEEE MTT-S Int. Microwave Symp. Dig.*, vol. 2, Seattle, WA, June 2002, pp. 1067–1070.
- [7] G. V. Eleftheriades, A. K. Iyer, and P. C. Kremer, "Planar negative refractive index media using periodically loaded L - C transmission lines," *IEEE Trans. Microwave Theory Tech.*, vol. 50, pp. 2702–2712, Dec. 2002.
- [8] A. Grbic and G. V. Eleftheriades, "A backward-wave antenna based on negative refractive index L - C networks," in *IEEE Int. Symp. Antennas and Propagation*, vol. 4, San Antonio, TX, June 16–21, 2002, pp. 340–343.
- [9] —, "Experimental verification of backwave-wave radiation from a negative refractive index metamaterial," *J. Appl. Phys.*, vol. 92, pp. 5930–5935, Nov. 2002.
- [10] I. V. Lindell, S. A. Tretyakov, K. I. Nikoskinen, and S. Iivonen, "BW media—Media with negative parameters, capable of supporting backward waves," *Microwave Opt. Tech. Lett.*, vol. 31, pp. 129–133, Oct. 2001.