

Diffraction

We know propagation mechanisms exist that allow us to receive signals even if there is no line-of-sight path to the receiver. Reflections off of objects is one propagation mechanism. Another significant propagation mechanism is *diffraction*, which allows radio signals to travel around around obstructions. It can be explained by Huygen's principle, which says that all points on a wavefront can be considered as points for the production of secondary wavelets, which subsequently combined to produce new waves in new directions. Hence, even if a region is shadowed by an obstruction, diffraction around the object's edges produces waves that propagate into the shadowed region.

1 Knife-Edge Diffraction

We will consider a simplified scenario, called *knife-edge diffraction*, which can be used to conservatively estimate more realistic diffraction effects. The obstruction is considered to be a "knife-like" edge protruding into the path between the transmitter and receiver. The geometry is shown in the illustration in Figure 1. The "screen" is assumed to have infinite width (i.e., it extends infinitely into and out of the page). No signals can penetrate the obstruction, therefore, some of the rays emanating from the transmitter will not reach the receiver. However, in an imaginary plane located in line with the obstruction, points above the obstruction can be considered secondary sources of wavelets, which combine to form waves propagating toward the receiver to the right of the screen.

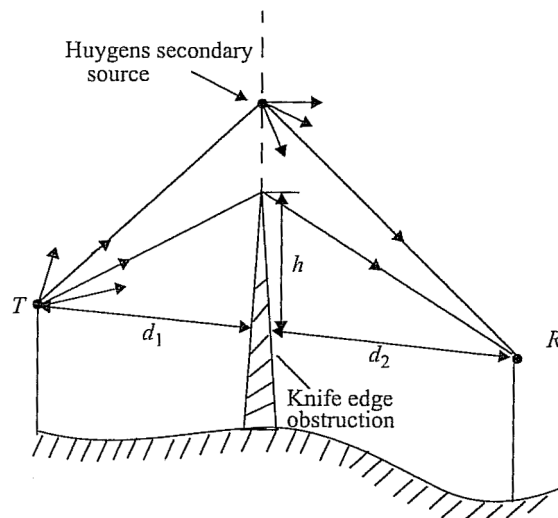

Figure 1: Knife-edge diffraction scenario

We will consider the contribution from one of these such waves. Then, by superposition, we can add up rays produced by all the sources above the obstruction and find the total field produced at the receiver. It is assumed that the polarization of these waves is unchanged in the process.

We start with a geometric situation shown below. The screen has a height h_{obs} , and the transmitter and receiver are at heights h_t and h_r , respectively. We consider two propagation paths from the

transmitter to the receiver: a line-of-sight path and a diffracted path. If we draw the line-of-sight (LOS) path from the transmitter to the receiver, the transmitter is a distance d_1 from the obstruction and the receiver is a distance d_2 from the obstruction, along this ray. The diffracted path makes an angle β with the horizontal on the transmitter side and an angle γ with the horizontal on the receiving side. As the transmitter and receiver are at different distances away from the obstruction, these angles are not necessarily equal.

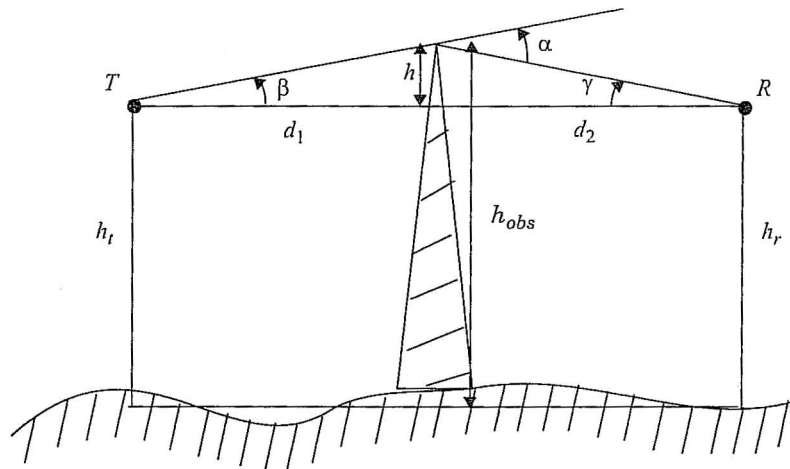

Figure 2: KED with $h_t = h_r$

In Figure 2, $h_t = h_r$. We can modify this geometry to account for different transmitter and receiver heights, as shown in Figure 3.

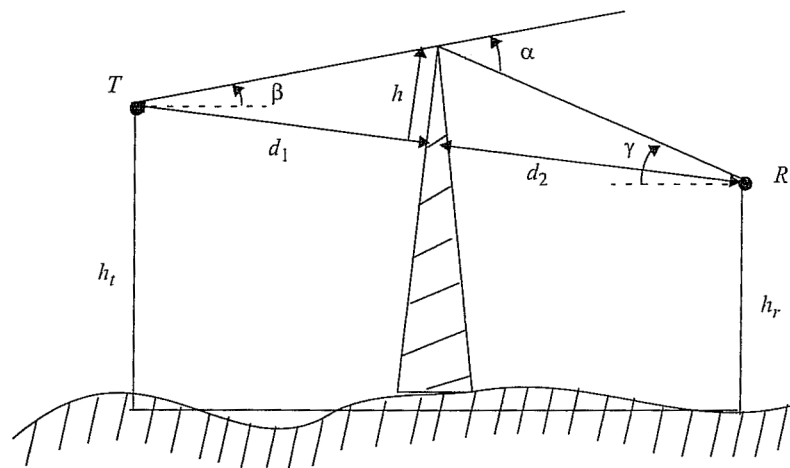

Figure 3: KED with $h_t \neq h_r$

For large d_1, d_2 , we can use the previous geometry, which assumed $h_t = h_r$, to simplify the analysis and it will remain approximately true for $h_t \neq h_r$, provided the separation distance is large compared to the heights. A simplified illustration is shown in Figure 4.

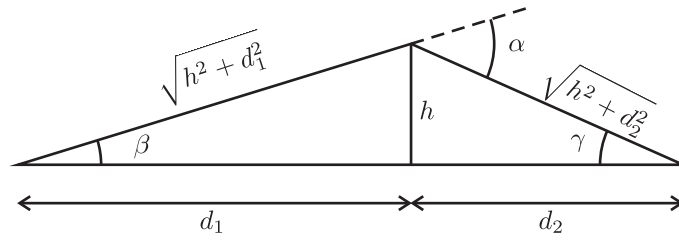

Figure 4: Simplified diffraction geometry

We are interested in finding the received electric field from the diffracted path shown, relative to the line of sight path. Its characteristics depend strongly on the path difference Δ between the length of the diffracted path and the length of the LOS path. Using the geometry shown Δ is easily found follows:

$$\Delta = \sqrt{d_1^2 + h^2} + \sqrt{d_2^2 + h^2} - (d_1 + d_2) \quad (1)$$

$$= d_1 \sqrt{1 + \frac{h^2}{d_1^2}} + d_2 \sqrt{1 + \frac{h^2}{d_2^2}} - d_1 - d_2 \quad (2)$$

$$\approx d_1 \left(1 + \frac{h^2}{2d_1^2}\right) + d_2 \left(1 + \frac{h^2}{2d_2^2}\right) - d_1 - d_2 \quad (3)$$

$$= \frac{h^2}{2} \left(\frac{1}{d_1} + \frac{1}{d_2}\right) \quad (4)$$

$$= \frac{h^2}{2} \frac{d_1 + d_2}{d_1 d_2} \quad (5)$$

The angle $\alpha = \beta + \gamma$. Since $d_1, d_2 \gg h$,

$$\beta = \tan^{-1} \frac{h}{d_1} \approx \frac{h}{d_1} \quad (6)$$

$$\gamma = \tan^{-1} \frac{h}{d_2} \approx \frac{h}{d_2} \quad (7)$$

$$\alpha = \alpha + \beta \approx \frac{h(d_1 + d_2)}{d_1 d_2} \quad (8)$$

The electrical length of the path difference is equal to

$$\phi = k\Delta = \frac{2\pi}{\lambda} \frac{h^2}{2} \frac{d_1 + d_2}{d_1 d_2} = \frac{\pi}{2} h^2 \frac{2}{\lambda} \frac{d_1 + d_2}{d_1 d_2} \quad (9)$$

Letting

$$v = h \sqrt{\frac{2(d_1 + d_2)}{\lambda d_1 d_2}} = \alpha \sqrt{\frac{2d_1 d_2}{\lambda(d_1 + d_2)}}, \quad (10)$$

where v is called the *Fresnel-Kirchoff parameter*, we can express ϕ as

$$\phi = \frac{\pi}{2} v^2 \quad (11)$$

where v is essentially the height of the screen multiplied by a frequency-dependent scalar. The second form of v above can be used when only the angles and distances are known (usually when the transmitter and receiver are at different heights).

We have computed path difference for one diffracted ray. The normalized electric field produced at the receiver, relative to the LOS path, is

$$\frac{E_d}{E_{LOS}} = \exp(-j\beta\Delta) = \exp\left(-j\frac{\pi}{2}v^2\right) \quad (12)$$

where the difference in received electric field magnitude is assumed to be zero.

Now we include the effect of all the other rays produced by the Huygen's sources. These are produced for all Huygen's sources above the screen, and hence we sum or integrate from v to infinity:

$$\frac{E_d}{E_{LOS}} = F(v) = \frac{1+j}{2} \int_v^\infty \exp\left(-j\frac{\pi}{2}t^2\right) dt, \quad (13)$$

$$F(v) = \frac{1+j}{2} \left[\int_v^\infty \cos\left(\frac{\pi}{2}t^2\right) dt - j \int_v^\infty \sin\left(\frac{\pi}{2}t^2\right) dt \right] \quad (14)$$

where a dummy variable t has been used in the integration so that the resulting expression is a function of v . A constant has been included so that $E_d/E_{LOS} = 1$ when $v = -\infty$ (no obstruction). $F(v)$ is called the complex Fresnel integral. A complex Fresnel integral is generally defined as:

$$C(v) - jS(v) = \int_0^v \exp(-j\frac{\pi}{2}t^2) dt \quad (15)$$

$$= \int_0^v \cos\left(\frac{\pi}{2}t^2\right) dt - j \int_0^v \sin\left(\frac{\pi}{2}t^2\right) dt \quad (16)$$

The Fresnel integrals $C(v)$ and $S(v)$ must be integrated numerically. We re-write the Fresnel integrals in the expression for the electric field to match these definitions of the Fresnel integrals.

For example

$$\int_v^\infty \cos\left(\frac{\pi}{2}t^2\right) dt = \int_0^\infty \cos\left(\frac{\pi}{2}t^2\right) dt - \int_0^v \cos\left(\frac{\pi}{2}t^2\right) dt \quad (17)$$

At infinity, the Fresnel integrals have values

$$C(\infty) = S(\infty) = \frac{1}{2}, \quad (18)$$

allowing us to write the normalized electric field as

$$F(v) = \frac{1+j}{2} \left\{ \left[\frac{1}{2} - C(v) \right] - j \left[\frac{1}{2} - S(v) \right] \right\} \quad (19)$$

Recall in Friis' formula we defined a free space loss term such that

$$\frac{W_r}{W_t} = \frac{G_t G_r}{l_{FS}} \quad (20)$$

or equivalently

$$\frac{W_r}{W_t} = G_t G_r g_{FS} \tag{21}$$

where g_{FS} is the free space inverse loss (or “gain”). We now include the effects of diffraction by defining

$$g_{diff} = |F(v)|^2 = \frac{1}{2} \left| \left[\frac{1}{2} - C(v) \right] - j \left[\frac{1}{2} - S(v) \right] \right|^2 = \frac{1}{l_{diff}} \tag{22}$$

so that

$$\frac{W_r}{W_t} = G_t G_r g_{FS} g_{diff} = \frac{G_t G_r}{l_{fs} \cdot l_{diff}} \tag{23}$$

g_{diff} or l_{diff} must be evaluated numerically. There is a reasonably good approximation for $g_{diff} = |F(v)|$ in dB defined by Lee as follows.

$$g_{diff}(\text{dB}) = \begin{cases} 0 & v \leq -1 \\ 20 \log(0.5 - 0.62v) & -1 \leq v \leq 0 \\ 20 \log(0.5 \exp(-0.95v)) & 0 \leq v \leq 1 \\ 20 \log(0.4 - \sqrt{0.1184 - (0.38 - 0.1v)^2}) & 1 \leq v \leq 2.4 \\ 20 \log\left(\frac{0.225}{v}\right) & v > 2.4 \end{cases} \tag{24}$$

A plot of g_{diff} and the approximation is plotted below.

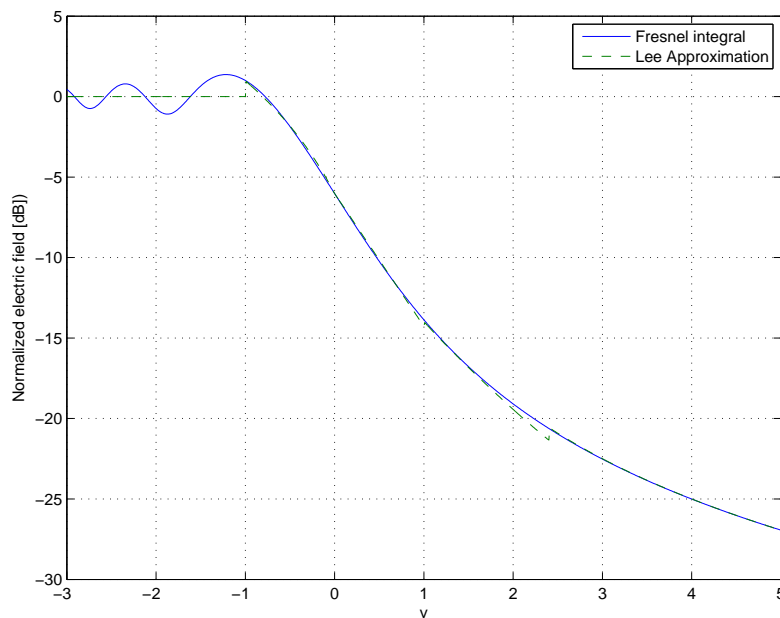

Figure 5: Diffraction gain as a function of v

A steep drop in g_{diff} is observed as commencing at $v = -1$, which corresponds to $\phi = \frac{\pi}{2}$ or a quarter wavelength of path difference between the tip of the obstruction and the LOS path.

The actual height of the obstruction depends on the geometry of the problem. However, if the obstruction is very close to the receiver ($d_1 \gg d_2$),

$$v = h \sqrt{\frac{2(d_1 + d_2)}{\lambda d_1 d_2}} \approx h \sqrt{\frac{2}{\lambda d_2}}$$

Solving when $v = -1$ gives

$$h = \sqrt{\frac{\lambda d_2}{2}}$$

which is the critical obstacle height. If the height is below this value, minimal diffraction effects will occur.

Example Given the geometry in Figure 6, determine a) the loss due to knife-edge diffraction and b) the height of the obstacle required to induce 6 dB of diffraction loss. Assume $f = 900$ MHz.



Figure 6: Example problem geometry

a) The wavelength is $\lambda = c/f = 1/3$ m. The angles β , γ and subsequently α can be determined as

$$\beta = \tan^{-1} \left(\frac{100 - 50}{10000} \right) = 0.2865^\circ,$$

$$\gamma = \tan^{-1} \left(\frac{100 - 25}{2000} \right) = 2.15^\circ,$$

$$\alpha = \beta + \gamma = 2.434^\circ = 0.0424 \text{ rad.}$$

The Fresnel-Kirchoff coefficient is then found using (10) as $v = 4.24$. Invoking the Lee approximation (24) or referring to Figure 1, the diffraction losses can be determined to be 25.5 dB.

b) For 6 dB of diffraction loss, $v = 0$. The obstruction height h can then be found using similar triangles ($\beta = -\gamma$) as

$$\frac{h}{2000} = \frac{25}{12000} \Rightarrow h = 4.16 \text{ m.}$$

Hence the obstacle height is $h_{obs} = 25 \text{ m} + 4.16 \text{ m} = 29.16 \text{ m}$.

2 Fresnel Zones

Consider the contribution from a single Huygen's source in the diffraction problem. It is elevated a distance h from the LOS ray. We notice that if the height h is chosen such that the path length differential between the diffracted path and LOS path Δ is one half-wavelength, the diffracted wave has incurred a 180° phase shift relative to the LOS wave. This is true over a locus of points forming a ring in the plane of the screen. Such a ring or circle is called a *Fresnel zone*. If we increase h further, such that $\Delta = \lambda$, we get a ring of sources that produce fields in phase with the LOS path at the receiver. This process repeats, giving us alternating Fresnel zones that provide constructive and destructive interference to the total received signal every $\lambda/2$ increase in h . We define the set of points at which propagation produces an excess path length of precisely $n\lambda/2$ to be called the n th Fresnel zone.

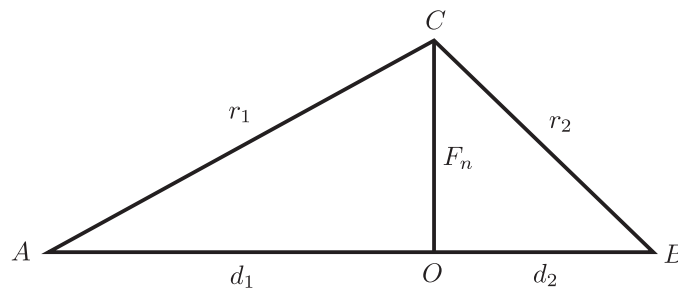

Figure 7: Fresnel zone radius illustration

The radius of the n th Fresnel zone circle can be found as follows. Consider the triangle below which shows a cross-section of the n th Fresnel zone. Path AB is the direct path and path ACB is the indirect path. The condition that will locate point C on the n th Fresnel zone is

$$r_1 + r_2 = d_1 + d_2 + n\lambda/2. \quad (25)$$

Hence,

$$\sqrt{d_1^2 + F_n^2} + \sqrt{d_2^2 + F_n^2} = d_1 + d_2 + n\lambda/2, \quad (26)$$

and since $F_n \ll d_1$, $F_n \ll d_2$, we can approximate this as

$$d_1 + \frac{F_n^2}{2d_1} + d_2 + \frac{F_n^2}{2d_2} = d_1 + d_2 + n\lambda/2. \quad (27)$$

Therefore,

$$\frac{F_n^2}{2} \left[\frac{1}{d_1} + \frac{1}{d_2} \right] = F_n^2 \frac{d_1 + d_2}{2d_1d_2} = n\lambda/2 \quad (28)$$

yielding

$$F_n = \sqrt{\frac{n\lambda d_1 d_2}{d_1 + d_2}} \quad (29)$$

Each circle of radius F_n has an excess path length of $\lambda/2$, λ , $3\lambda/2$, etc. for $n = 1, 2, 3, \dots$. Note that r_n depends on the distances d_1 and d_2 to the obstruction and that r_n is maximum when $d_1 = d_2$. The circles shrink as the obstruction is moved closer to the transmitter or receiver.

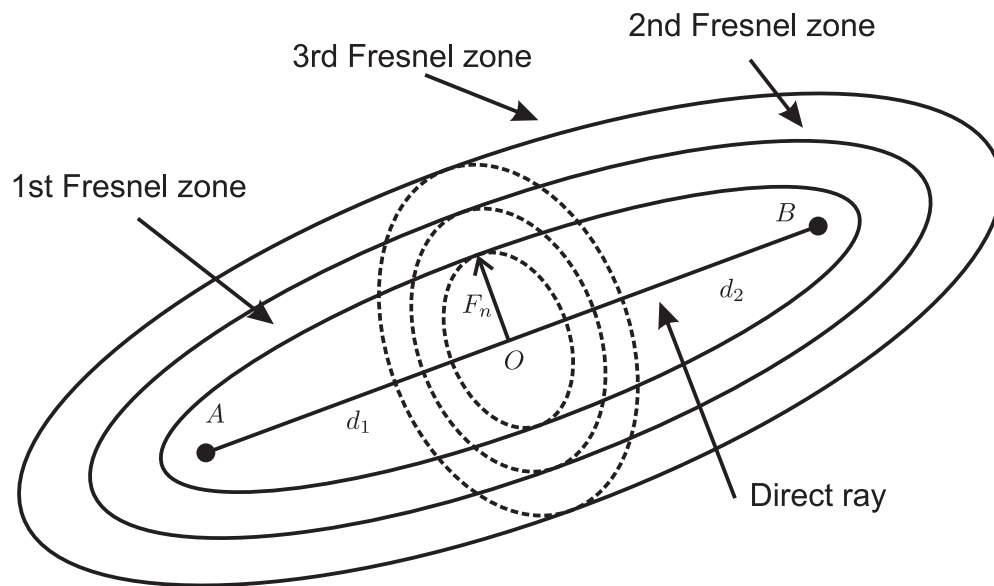

Figure 8: Fresnel zones

If we join all the points between the transmitter and receiver for which Δ is an integer multiple of $\lambda/2$ (effectively drawing Fresnel zones in 3D), we obtain ellipsoids, as shown in Figure 8. Various degrees of obstruction are illustrated in Figure 9.

The relevance of Fresnel zones and the knife-edge diffraction study can be seen by considering a more realistic diffraction scenario, shown in Figure 10. Here, h actually denotes the clearance height, unlike the definition of (10), so for these purposes we should think of h as negative. The cases consider a spherical diffraction obstacle, which is obviously quite different than a knife-edge obstacle. However, the diffraction from a spherical obstacle can be carried out numerically, and can be used to simulate terrain blocking the path between the transmitter and receiver.

The results of such calculations are shown in the graphs in Figure 11, which are plotted as a function of the obstacle height normalized with respect to the first Fresnel zone radius. Here, curve A represents the diffraction from a perfectly conducting earth sphere, which is obviously unrealistic but a canonical case that can be easily computed. Curve C represents the diffraction curve from a lossy earth assuming realistic values for ground conductivity, and hence represents a much more accurate situation. Curve B shows the result from a knife-edge diffraction calculation like what we have carried out. Clearly, curves B and C are very similar, so knife-edge diffraction actually does a reasonable job of predicting earth diffraction but with much less computational effort.

The second thing we notice is that regardless of the calculation technique used, there is a special point $h/F_1 = 0.6$ where the diffraction gain/loss is equal to that if there was no obstacle present (i.e. free space gain/loss). That is, the path is cleared by approximately 0.6 times the radius of the first Fresnel zone at the location of the obstacle. This tells us that diffraction effects can be effectively neglected provided that more than 60% of the first Fresnel zone radius is not obstructed. This can be thought of the 3D equivalent of the $\lambda/4$ rule we discussed earlier.

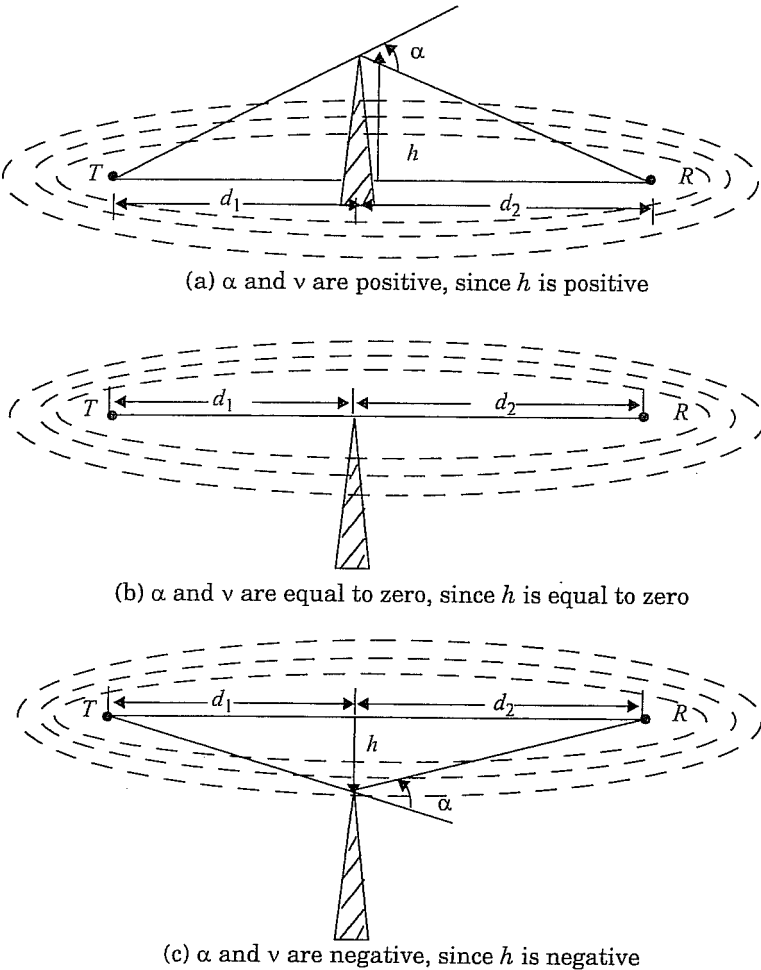

Figure 9: Cases of Fresnel zone blockage

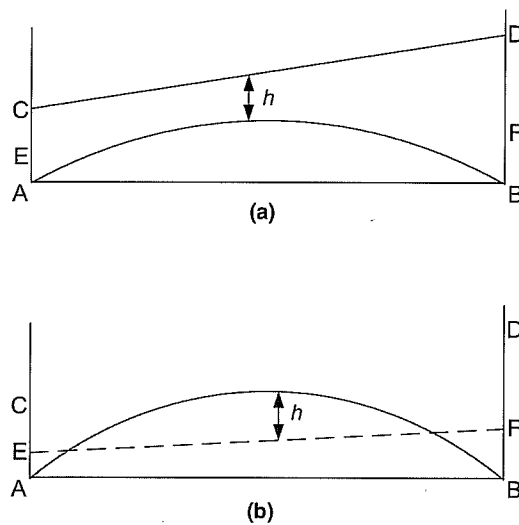

Figure 10: Realistic diffraction cases. If h is re-defined to be the clearance height, the top picture show $h > 0$ and the bottom show $h < 0$. Note this is the opposite convention of (10).

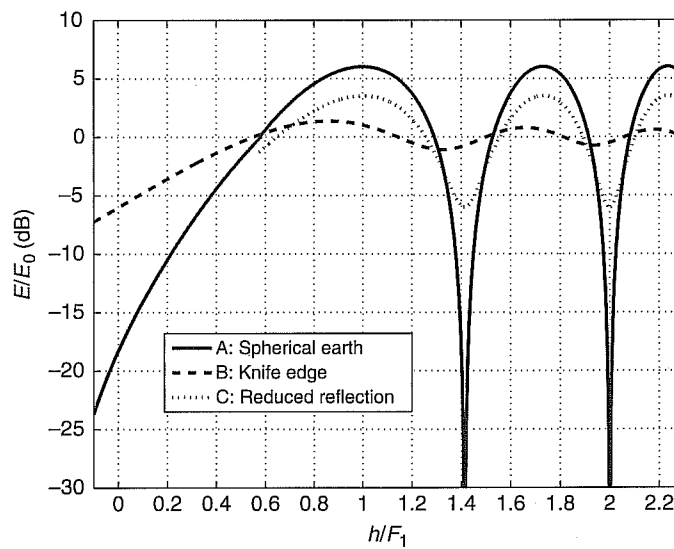

Figure 11: Comparison of diffraction calculations for various cases

3 Multiple Knife-Edge Diffraction

If the propagation path is obstructed by more than one obstruction, the total diffraction loss of all the obstacles must be computed. This is obviously a challenging task that is realistically simplified by using computers to ray-trace and compute the diffraction. But a very (overly) simple approach can be obtained by replacing a series of obstacles with a single equivalent obstacle, as shown in Figure 12. This approach usually gives an optimistic value of the received power, but is not a bad approximation.

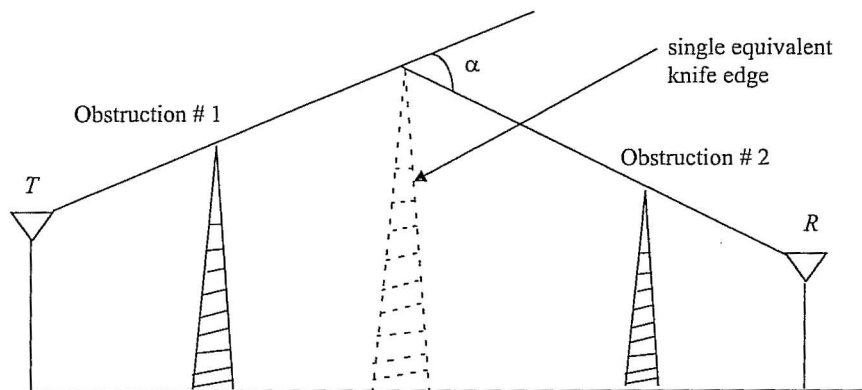

Figure 12: Multiple obstruction diffraction